

AIR BLOWER INGROUND VAULT

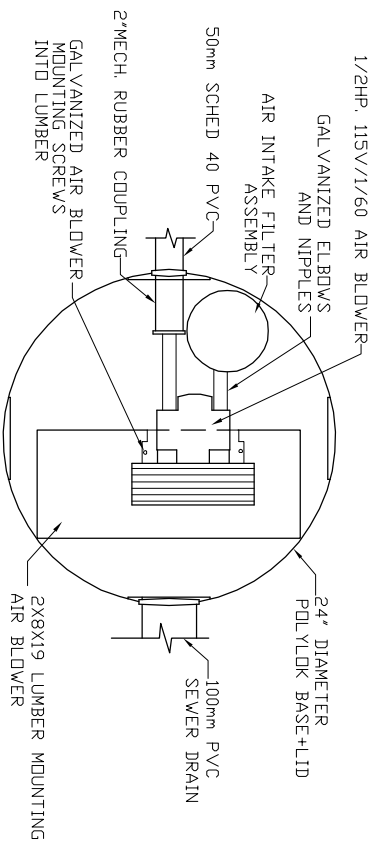

TOP VIEW
N.T.S.

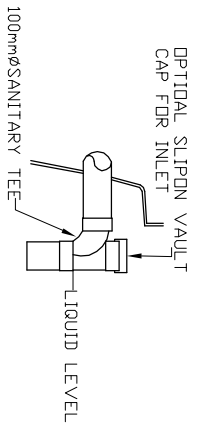

INLET DETAIL
N.T.S.

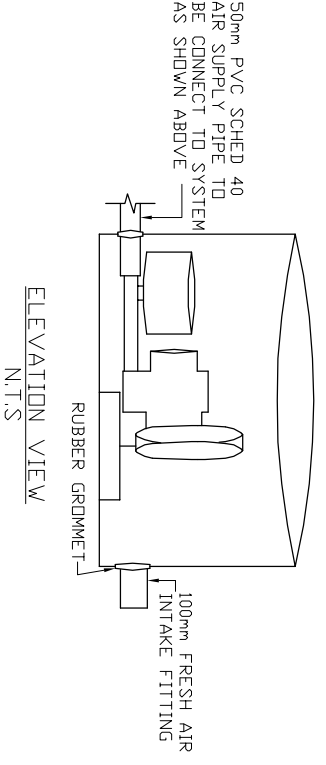

ELEVATION VIEW
N.T.S.

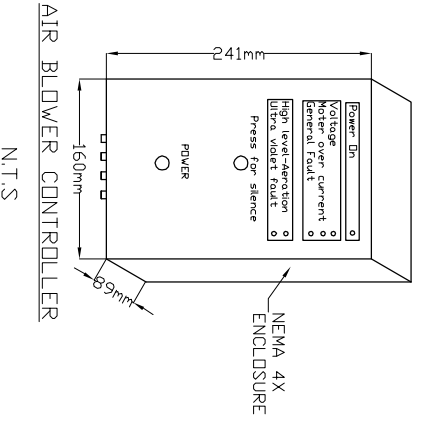

- MicroFAST® 1.0**
TANK MANUFACTURED BY
ABC PRECAST INC
- SYSTEM IS DELIVERED FACTORY
PRE-ASSEMBLED
1. CONCRETE TANK MANUFACTURER'S MODEL NO: 1200-1PC-2CH REFER TO MANUFACTURERS SPECIFICATION FOR TANK AND BURIAL INSTALLATION GUIDELINES
 2. OPERATING CONDITION
3,791 LITRES (1000us gals) (834 imp gals) PER DAY OF DOMESTIC RESIDENTIAL SEWAGE INFLUENT
BOD = 250 mg/l
TSS = 250 mg/l
FATS, OIL GREASES = 35 mg/l
 4. EFFLUENT (capabilities)
BOD = 10 mg/l
TSS = 10 mg/l
TOTAL NITROGEN = 70% Reduction
 5. VOLUMETRIC CAPACITY
1ST CHAMBER = 1,816 L
2ND CHAMBER = 3,640 L
 6. DRY SHIPPING WEIGHT = 6,150 kg
 7. BURIAL DEPTH MAXIMUM EARTH COVER (ND CLAY) 610mm
 8. FOR INSTALLATION, REFER TO CSA B66, BC SEWERAGE SYSTEM STANDARD PRACTICE MANUAL AND INSTALLATION GUIDELINES PUBLISHED BY PINNACLE ENVIRONMENTAL TECHNOLOGIES INC.
 9. DIMENSIONS in mm.
 10. INLET AND OUTLET ACCEPT 100mm S/D COUPLING
 11. EXTENSION FOR SERVICE ACCESS HATCHES AVAILABLE ON REQUEST.
 12. MAXIMUM EARTH COVER AS MEASURED FROM TANK TOP CENTRE LINE (NOT INCLUDING RISERS) IS 610mm.
 13. FOR HIGH WATER TABLE INSTALLATION CONTACT PINNACLE PRIOR TO ORDERING.
 14. FOR VEHICLE TRAFFIC CONTACT PINNACLE PRIOR TO ORDERING.

| | | | | | |
|--------------|---------------|---|--|-------|-------------|
| Drawing No: | ABC 1000-2-01 | Project Title/Description MicroFAST® 1.0 | Pinnacle Environmental Technologies Inc. Mailing Add: Location: P.O. Box 12112 22867-FraserHwy, Langley, BC, V3A 9J Langley, BC Ph: 604-514-7555 Fx: 604-514-7595 Email: info@peti.ca WebSite: www.peti.ca | | |
| Revision No: | 0 | | | | |
| Sheet No: | 1 of 1 | | | | |
| Drawn By: | S. Mann | Scale: | 1:50 | Date: | 12.Oct.2011 |